

MIX Contemporary Mobile Assembly Instructions

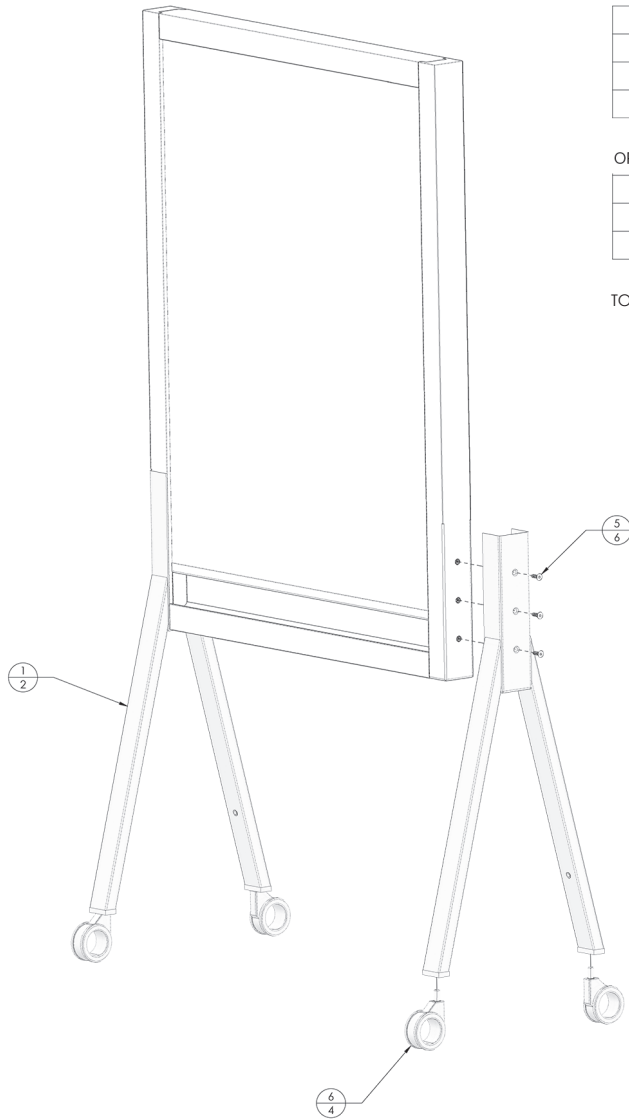

PARTS LIST

ITEM NO.	PART NUMBER	DESCRIPTION	QTY.
1	20-18121303.1	WELDMENT, LEG, CONTEMPORARY, TALL	2
2	4120044	SCREW, STEEL ZINC PLTD, 1/4-30X0.875, FSH w/NYLOK	4
3	4120045	MIX CONTEMPORARY CASTER	4

OPTIONAL SHELF PARTS

4	4120040	ALLEN BOLT, STEEL ZINC PLTD, 1/4-20x1.000, SH	4
5	4120038	WASHER, STEEL ZINC PLTD, 1/4" FLAT	6
6	4120039	WASHER, STEEL ZINC PLTD, 1/4" SPLIT LOCK	4

TOOLS NEEDED: 14mm wrench, Allen wrench

MIX Unit Assembly

1. Place pre-assembled board on a flat surface clear or protected from any debris that may scratch the finish of the board. Make sure bottom side (the end with the leg mounting holes) overhang the surface edge safely.
2. Collect the appropriate mounting hardware for one leg - 3 mounting screws
3. Place appropriate right/left leg on the bottom end section with matching pre-drilled holes
4. Thread screw through a mounting hole and tighten with an Allen wrench
6. Repeat step 4 for remaining holes
7. Repeat steps 2 through 4 for opposite leg

Mount Leg Casters

1. Collect the 4 casters provided
2. Take one caster and thread the mounting bolt into the pre-tapped receiver socket on the bottom of the leg
3. Tighten with a 14 mm wrench
4. Repeat steps 2 and 3 for remaining casters

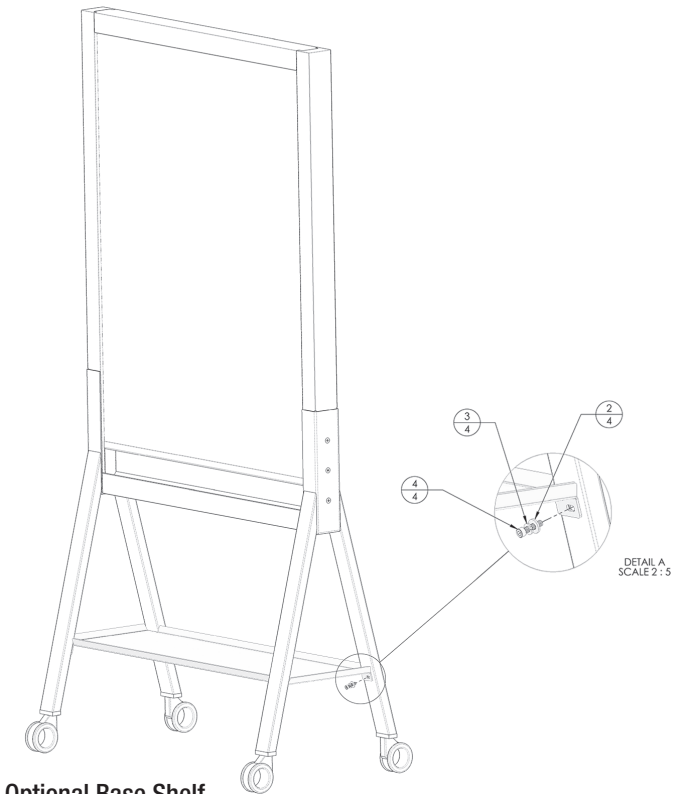

Optional Base Shelf

1. Collect the optional tray
 - a. 4 bolts (#4120040)
 - b. 4 lock washers (#4120039)
 - c. 4 flat washers (#4120038)
2. Place tray in the location between unit legs located by the mounting holes. The tray is keyed to allow only correct shelf orientation
3. Place 1 lock washer, then 1 flat washer on an Allen bolt, slide washers to the head of the bolt (see diagram A)
4. Thread the bolt through the bolt hole on the mounted tray into the pre-tapped hole in the leg and tighten with an Allen wrench
5. Repeat Steps 3 and 4 for remaining mounting holes



800.434.4610
claridgeproducts.com