

# MIX Industrial Mobile Assembly Instructions

## PARTS LIST

ITEM NO.	PART NUMBER	DESCRIPTION	QTY.
1	20-18121301.1	WELDMENT, LEG, INDUSTRIAL, TALL, JET BLACK	2
2	4120028	BOLT, STEEL ZINC PLTD, 1.2-13x3.750, HEX HD	4
3	4120031	MIX INDUSTRIAL CASTER	4
4	4120034	NUT, ZINC PLTD, 1/2-13, HEX	4
5	4120035	WASHER, ZINC PLTD, 1/2" FLAT	4
6	4120036	WASHER, STEEL ZINC PLTD, 1/2", SPLIT LOCK	4

## OPTIONAL SHELF PARTS

7	4120038	WASHER, STEEL ZINC PLTD, 1/4" FLAT	4
8	4120039	WASHER, STEEL ZINC PLTD, 1/4" SPLIT LOCK	4
9	4120040	ALLEN BOLT, STEEL ZINC PLTD, 1/4-20x1.000, SH	4

TOOL NEEDED: Allen wrench

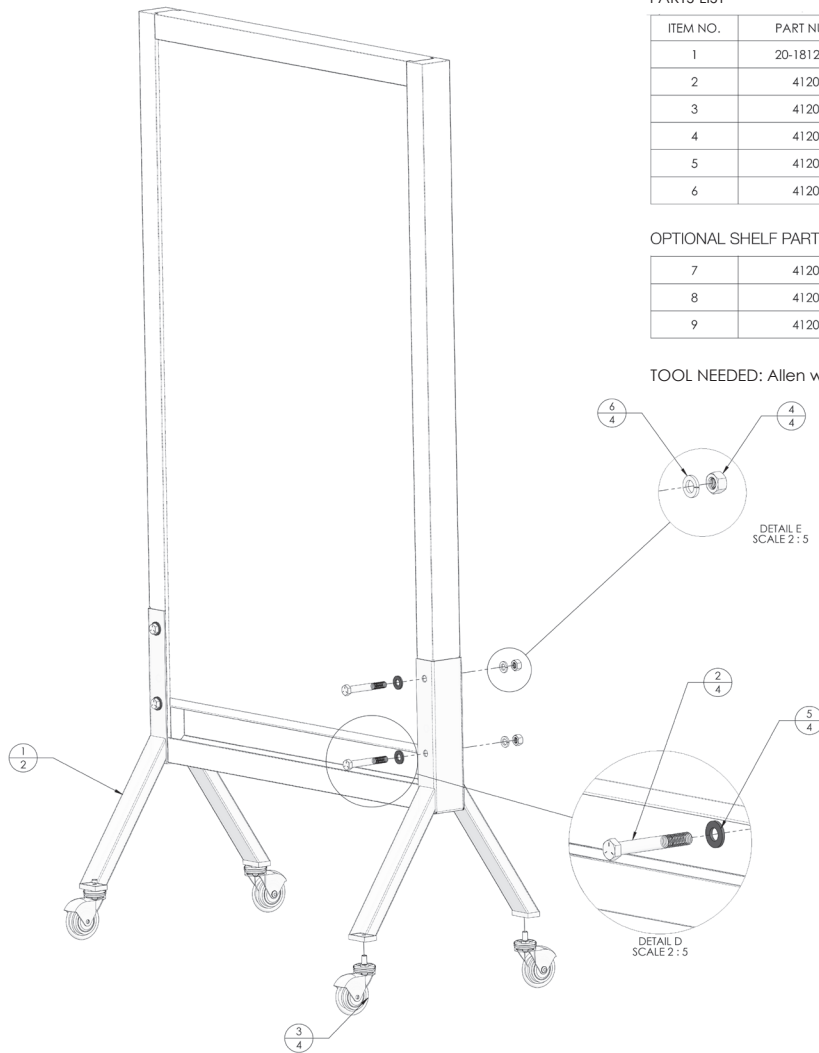

## MIX Unit Assembly

- Place pre-assembled board on a clear flat surface protected from any debris that may scratch the finish of the board. The bottom side (the end with the leg mounting holes) should overhang the surface edge safely.
- Collect the appropriate mounting hardware for one leg
  - 2 bolts (#4120028)
  - 2 washers (#4120035)
  - 2 hex nuts (#4120034)
  - 2 flat washers (#4120036)
- Place appropriate right/left leg on the bottom end section with matching pre-drilled holes
- Place a flat washer (#4120035) on the bolt end (#4120028) and slide it to the pre-assembled board; place a locking washer on the exposed thread end (see detail D)
- Thread the hex nut (#4120034) onto the hex bolt and tighten
- Repeat steps 4 through 5 for remaining holes
- Repeat steps 2 through 6 for opposite leg

## Mount Leg Casters

- Collect the 4 casters provided
- Take one caster and thread the mounting bolt into the pre-tapped receiver socket on the bottom of the leg and hand tighten
- Repeat step 2 for remaining casters

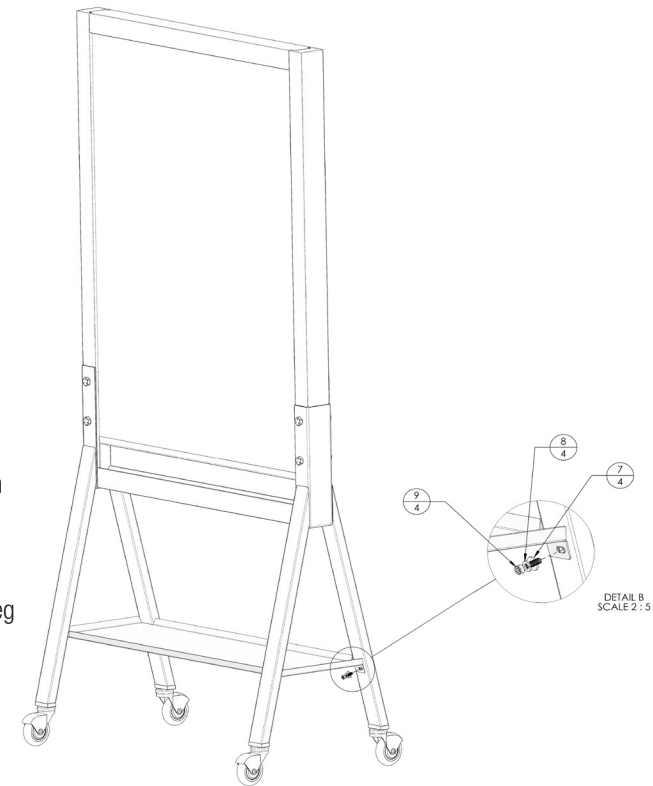

## Optional Base Shelf

- Collect: the optional tray
  - 4 bolts (#4120040)
  - 4 lock washers (#4120039)
  - 4 flat washers (#4120038)
- Place tray in the location between unit legs located by the mounting holes. The tray is keyed to allow only correct shelf orientation
- Place 1 lock washer, then 1 flat washer on an Allen bolt, slide washers to the head of the bolt (see detail B)
- Thread the bolt through the bolt hole on the mounted tray into the pre-tapped hole in the leg and tighten with an Allen wrench
- Repeat Steps 3 and 4 for remaining mounting holes