

XCHANGE

Changeable Graphics Board



The Xchange Graphic Markerboard is designed with versatility in mind because communication needs are always evolving. This customizable board features an interchangeable graphic insert that slides easily behind a clear, 1/4" tempered glass writing surface. Ideal for medical patient rooms, hospitality event scheduling, performance reviews, and more.

- Rigid, lightweight easy-to-change custom graphic insert
- Swap out the custom graphic to update scene, seasonal images or messages
- Low profile aluminum trim top and bottom in black or white colors

XCHANGE

Changeable Graphics Board



SPECIFICATIONS

- Low profile aluminum trim top and bottom, with black or white color finish
- Interchangeable custom graphic insert, printed in 4-color process using UV curable inks

STANDARD SIZES (HxW)

- 1.5' x 2'
- 2' x 3'
- 3' x 4'

[LEARN MORE](#)



NOTE: File requirements for high-resolution logos or graphic file. Images or logos should be submitted in high-resolution .jpeg, .pdf, .eps, or .ai format. If usable file is unavailable, ADD \$75 NET per hour - minimum one-hour charge - for creating graphics.



XCHANGE

Changeable Graphics Board

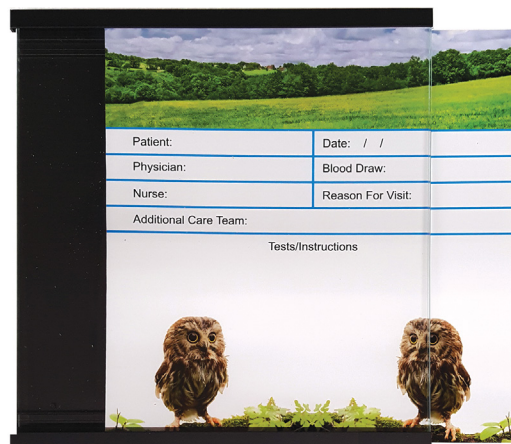

ASSEMBLY INSTRUCTIONS

- After unpacking and inspecting your new Xchange board, lay on a flat surface and remove graphic insert.

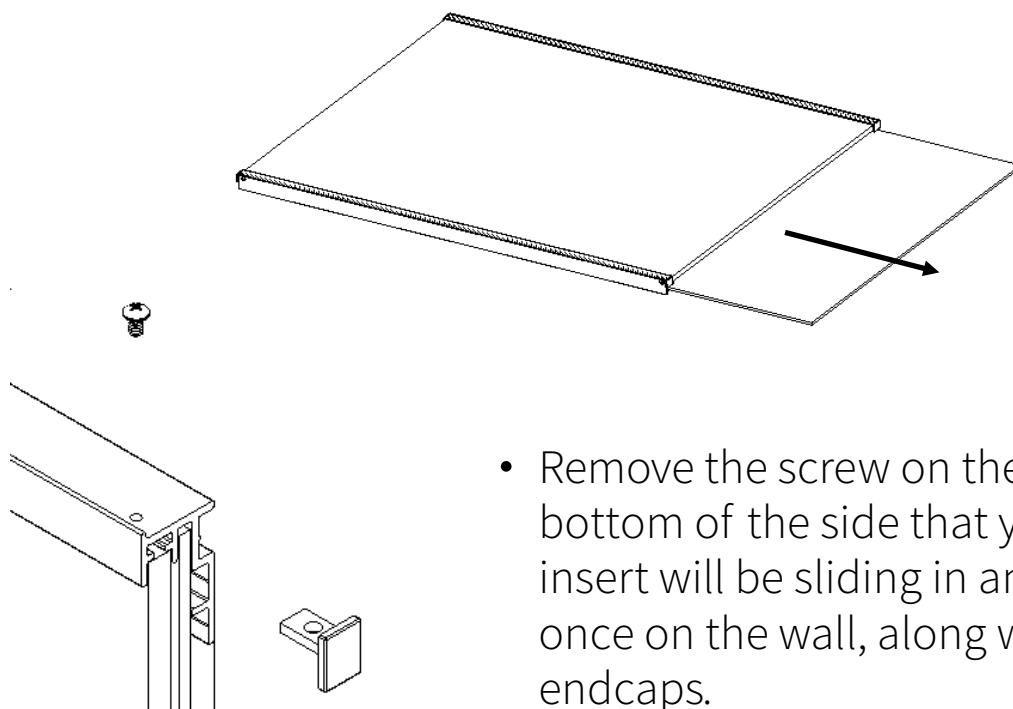

- Remove the screw on the top & bottom of the side that your graphic insert will be sliding in and out of once on the wall, along with plastic endcaps.

WARNING

Risk of injury to installers and users
Read the entire assembly directions before
beginning assembly.

Xchange Board

Assembly

Gently remove the glass and place in a safe place.

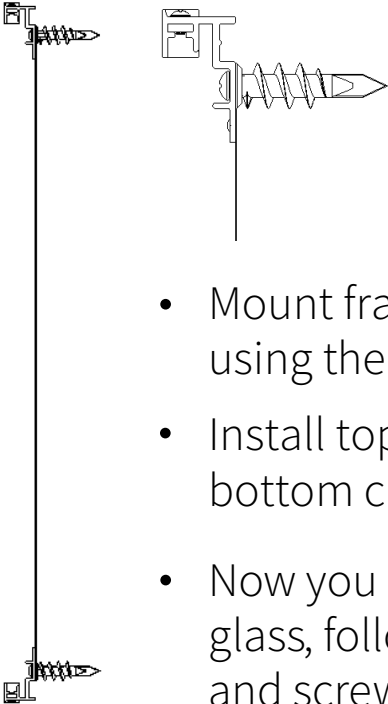
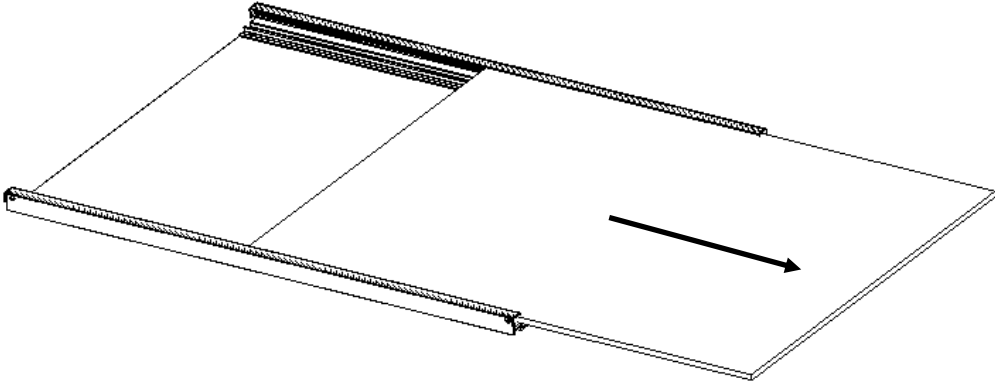

- Mount frame in desired location, using the appropriate wall anchors.
- Install top channel followed by the bottom channel.
- Now you are ready to reinsert your glass, followed by the endcaps and screws.
- Finally reinstall your graphic insert.

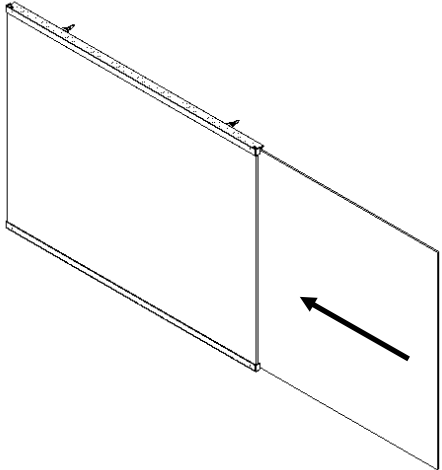
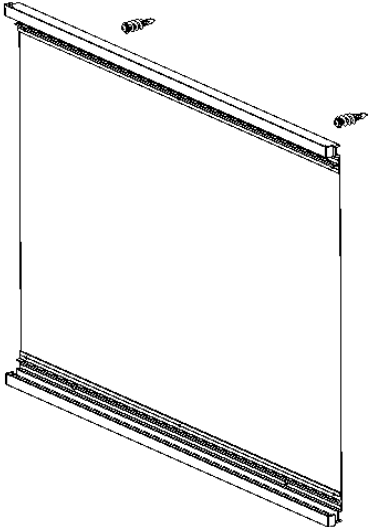

800-434-4610
claridgeproducts.com

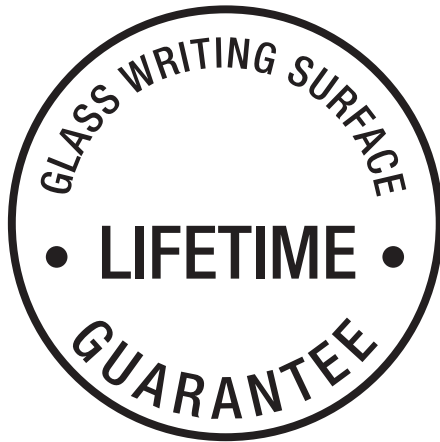

When properly installed in a suitable environment and under normal intended usage, care and maintenance, including the use of proper markers, erasers and cleaners; Claridge Glass markerboard writing surfaces are guaranteed for the Life of the Building.

This warranty excludes, among other things, any and all damages resulting from earth movements or any other natural and/or man-made disasters. We do not recommend the use of abrasive cleaners on the glass surface as they may dull or “pit” the surface of the glass. Guarantee covers replacement of defective surfaces but does not include damage to the edge of the glass board, cost of removal or re-installation.



Under normal usage and maintenance, Claridge products are guaranteed for one year.

This guarantee covers repair or replacement of the manufactured parts that fail in materials or workmanship within the specified warranty period. Guarantee covers replacement of defective parts only and does not include cost of removal or re-installation.



SCS Global Services does hereby certify that an independent assessment has been conducted on behalf of:

Claridge Products & Equipment

480 Wrangler Drive
Suite 200, Coppell, 75019, United States

For the following product(s):

See Addendum

The product(s) meet(s) all of the necessary qualifications to be certified for the following claim(s):

Indoor Advantage™ Gold

Indoor Air Quality Certified to SCS-105 v4.2

Conforms to the ANSI/BIFMA Furniture Emissions Standard (M7.1/X7.1-2011 R2021) and ANSI/BIFMA e.3-2019 (Credits 7.6.2, 7.6.3) for the open plan and (Credits 7.6.1, 7.6.2, 7.6.3) private office workstation parameters.¹ Also, conforms to the CDPH/EHLB Standard Method (CA 01350) v1.2-2017 for the open plan and school classroom parameters.¹

¹Modeled as Individual Furniture Components

Registration # SCS-IAQ-09072

Valid from: November 04, 2024 to June 08, 2025



INDOOR ADVANTAGE GOLD
FURNITURE



Diana Kirsanova Phillips, Chief Assurance
Officer,
SCS Global Services

Certification Addendum

Claridge Products & Equipment

Certification: Registration # SCS-IAQ-09072 | Valid from: November 04, 2024 to June 08, 2025

Addendum **Indoor Advantage™ Gold**

Conformance: Indoor Air Quality Certified to SCS-105 v4.2

Conforms to the ANSI/BIFMA Furniture Emissions Standard (M7.1/X7.1-2011 R2021) and ANSI/BIFMA e.3-2019 (Credits 7.6.2, 7.6.3) for the open plan and (Credits 7.6.1, 7.6.2, 7.6.3) private office workstation parameters.¹ Also, conforms to the CDPH/EHLB Standard Method (CA 01350) v1.2-2017 for the open plan and school classroom parameters.¹

¹Modeled as Individual Furniture Components

Products:

Visual Display Boards:

3300 Series Tackboard, 3400 Series Tackboard, 344 Wave Lectern, 370 Series Recessed Display Case, 390 Large Door Recessed Display Case, 725 Folding Screen, 748 Universal Display Case, 79 Hang-Tight Rail System, 800 Series Markerboard, 800 Series Tackboard, 800 Series Type BR/BL Combo Markerboard Tackboard, 900A Tackboard, 94 Combination Map Rail & Clip Strip, Aceno Room Divider Panels-Base, Aceno Track System, Arise Marker Walls, Arise Markerboard, Aspire Markerboards, Claridge LCS Porcelain, Classic Series Bulletin Board Cabinet, Classic Series Display Case, Concept Markerboard, Concept Tackboard, Connect X2 3 Caster Mobile Markerboard, Connect X2 Combination Markerboard/Tackboard, Connect X2 Full Height Mobile Markerboard Porcelain-Glass, Connect X2 Markerboard Porcelain-Glass, Connect X2 Partial Height Markerboard, Connect X2 Space Creator Porcelain-Cork-Fabric, Connect X2 Tackboard, Contemporary Series Bulletin Board Cabinet, Contemporary Series Bulletin Board Cabinet, Contemporary Style Laminate Lecture Unit, Contio Mobile Markerboard, CS Clip Strips, Cursive Board, Cursive One Markerboard-Tackboard, Custom Printed Glass Boards, Deluxe Series Bulletin Board Cabinet, Deluxe Series Revolving Two-sided Mobile Markerboard, Deluxe Two-sided Mobile Markerboard, Display Case-Cabinet, Economy and Deluxe Map & Display Rail, Edify Mobile Markerboard, EDR Exhibit Rail, Envision Graphics Markerboard, Economy and Deluxe Map & Display Rail, Evolve Markerboard, Evolve Sliding System, Evolve Tackboard, EZ Fit Markerboard Panel, Framed Tackboard, Glass Marker Walls, Glass Markerboards, Horizontal Sliding Markerboards, Imperial Series Bulletin Board Cabinet, Large Contemporary Series Bulletin Board Cabinet, Large Format Glass Marker System, Large Format Porcelain Marker System, LCS Deluxe Markerboard-Aluminum Frame,

Certification Addendum **Claridge Products & Equipment**

Certification: Registration # SCS-IAQ-09072 | Valid from: November 04, 2024 to June 08, 2025

Addendum **Indoor Advantage™ Gold**

Conformance: Indoor Air Quality Certified to SCS-105 v4.2

Conforms to the ANSI/BIFMA Furniture Emissions Standard (M7.1/X7.1-2011 R2021) and ANSI/BIFMA e.3-2019 (Credits 7.6.2, 7.6.3) for the open plan and (Credits 7.6.1, 7.6.2, 7.6.3) private office workstation parameters.¹ Also, conforms to the CDPH/EHLB Standard Method (CA 01350) v1.2-2017 for the open plan and school classroom parameters.¹

¹Modeled as Individual Furniture Components

Products:

Visual Display Boards Continued:

LCS Deluxe Markerboard-Aluminum Frame No Map Rail, LCS Deluxe Markerboard-Wood Frame, LCS Elite Markerboard, LCS Select Markerboard, LCS Wall-Write Marker Wall, LCS-Glass Combo Boards, Magnetic Glass Markerboard, Magnetic Non-Glare Glass Markerboard, Marker Walls, Merit Series Markerboard, Mina Mobile, Mina Space Creator, Non-Magnetic Non-Glare Glass Markerboard, Premier Wall Mounted Display Case, Premiere Freestanding Display Case, Premiere Series Reversible Mobile Markerboard w/ aluminum trim, Profile Frameless LCS Porcelain Markerboard, Revere Series Bulletin Board, Revere Series Bulletin Board Cabinet, Ripple Space Divider Acoustic-Acrylic, Series 1 Markerboard, Series 1 Tackboard, Series 5 Markerboard, Series 5 Tackboard, Series 2 Markerboard, Series 2 Tackboard, Series 2500 Markerboard, Series 3 Markerboard, Series 3 Tackboard, Series 4 Markerboard, Series 4 Tackboard, Series 8 Markerboard, Series 8 Tackboard, Sliding Marker Wall Systems Porcelain-Glass, Switch Markerboard Porcelain-Glass, Switch Mobile Markerboard Porcelain-Glass, Tableau Markerboard Porcelain-Glass, Tableau Tackboard, Tack Wall, TacPads Acoustic Fabric-Wrapped, Trak-it-system, TrimLine Markerboard, Universal Series Bulletin Board Cabinet, Utility A-Frame Mobile Markerboard, Venue Markerboard Porcelain-Glass, Venue Space Divider Porcelain-Glass Acoustic, Venue T-Leg Mobile Markerboard porcelain-Glass, Venue V-Leg Mobile Markerboard Porcelain-Glass, Vertical Sliding Markerboards, Xchange Graphic Board

Excludes products with wood trim. Excludes products manufactured with a cork substrate. Tackboard included are constructed with a fabricork or designer fabric over Duracore or Micore.